

Corporate Headquarters
BLACK BROS. CO.
501 Ninth Avenue
P.O. Box 410
Mendota, IL 61342-0410
Phone: 815.539.7451
Fax: 815.538.2451
<http://www.blackbros.com>
E-mail: info@blackbros.com

Southeast
BLACK BROS. CO.
SOUTHEAST DIVISION
1315 Baker Road
P.O. Box 4226
High Point, NC 27263-4226
Phone: 336.431.9145
Fax: 336.431.9275

Midwest
BLACK BROS. CO.
MIDWEST DIVISION
1420 West Armstrong Dr. (46580)
P.O. Box 1014
Warsaw, IN 46581-1014
Phone: 219.269.4630
Fax: 219.269.5291

Southcentral
BLACK BROS. CO.
Cedar Hills, TX 75106
Phone: 800.532.6159
Phone: 241.244.8394
Fax: 972.293.1618

Expert Service & Prompt Support



Our customers have found fertile ground for new ideas, technologies, and approaches. And they're comfortable with the systematic approach we suggest to solve their problems. Our knowledgeable sales engineers and technicians work closely with the customer to carefully review the specific application, material, and specification. In-house tests using lab and production machinery simulate real-world conditions. Only then are machinery and system recommendations made from our vast array of proven machine designs, controls, and optional equipment.

Our service and support is second to none. We offer ongoing training seminars for your operators and maintenance personnel. All Black Bros. machinery is backed by our strategically located Sales/Service Centers, providing fast, responsive support in the field.

When you own Black Bros. equipment, you can be certain that you have the finest machinery and support available in the world





Air Pod and Power Pod Presses



*At the forefront of
laminating and coating
technology for more
than a century.*

Black Bros. Air Pod Presses Tackle the Big Jobs

Black Bros. Air Pod Presses are well known for being rugged and dependable. That's why they've been selected for hundreds of different applications around the world. Plus, no other line of laminating presses offers the same combination of features and capabilities – not to mention Black Bros.' century of experience, technical know-how, and support services.

Choose from a variety of arrangements to best suit your requirements. Air Pod Presses come in 10, 50, and 80 PSI models, in a complete range of sizes from 2' x 4' (610 mm x 1279 mm) on up, and pressure ratings up to 350 tons (317 metric ton) based on a 5' x 12' (1524 mm x 3658 mm) press.

Press ratings indicate pressure per square inch over the full platen area.



1. Long-Life Air Pods

Pods are made of durable neoprene-covered fabric in a double convolute configuration. Standard stroke is 5" (127 mm). Air requirements are very minimal.

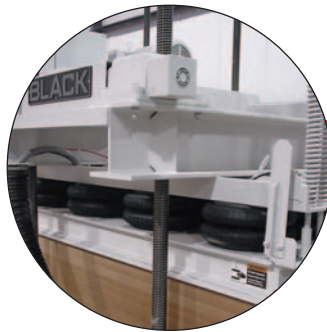

2. Motorized Adjustment

Presses with this feature can quickly accommodate any height stack within its capacity simply by pressing the "Up" or "Down" button. No blocking or filling is required as with non-motorized models. The downward movement automatically stops when the sensor on the top platen contacts the load. This feature is ideal where load heights vary due to customer requirements, or to accommodate short loads occurring at the end of a run or shift.

or

Manual Screw Adjustment

Non-Motorized Air Presses come equipped with threaded support rods to enable top platen to be raised or lowered manually, eliminating the need for cumbersome filler panels to close the gap between the top of the stacks and the top platen.



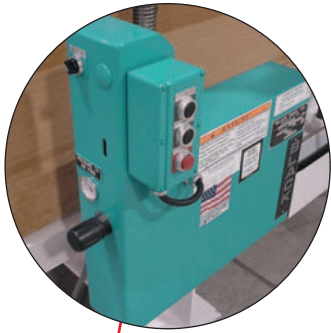

4. Convenient Controls

All controls are conveniently located in the easily accessible control panel module mounted on the press.

5. End- or Side-loading

Various line and plant configurations can be accommodated with either end- or side-loading versions. End-loading design is normally recommended for in-line panel and door operations. Side-loading permits entry/exit from the sides. Side-loading is ideal when two or more stacks are laminated in multi-platen presses – typical for cut-to-size pieces.

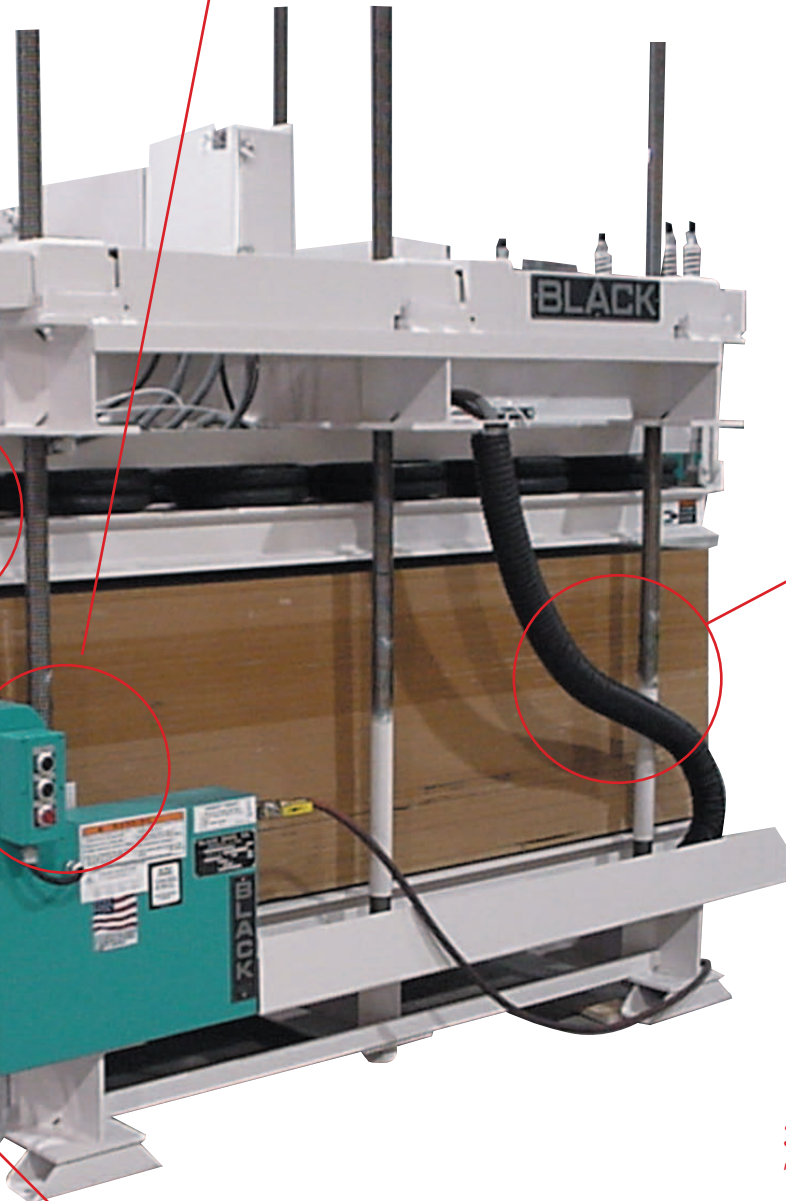
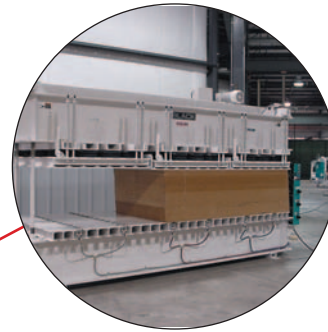

3. Air-Loaded Roller Tracks

Press loading and unloading is easily accomplished with the air-activated roller tracks that elevate when platen air is off. After the load is positioned and air pressure is activated, the rollers recess into the platen.

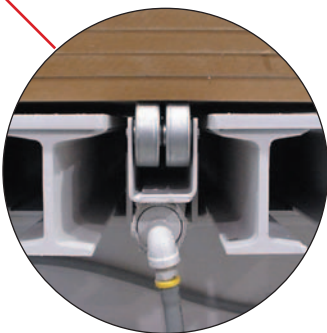

Other unique standard features include:

- H-Beam Frames for added rigidity, precise adjustment, and uniform platen pressure.
- Heavy-Duty Springs quickly return the top platen to its pre-set height after air is released.
- Precision-Machined Platens provide uniform pressure to insure flat panels.
- Limit Switches prevent over-expansion of pods, and for upward and downward platen movement.
- Only Black Bros. Air Pod Presses offer all of these exclusive design features for increased production, fewer rejects, and minimal maintenance.

Optional Equipment Boosts Productivity and Versatility

Black Bros. offers a variety of machine and system configurations to best meet your specific production requirements as well as add versatility.



Multi-platen:

For side loading presses. Presses with two or more platens located on a common upper frame can be controlled individually to bond various size loads, or in unison to bond a larger load. This arrangement can also increase output by allowing simultaneous loading and pressing of stacks on alternate platens, allowing one press to perform as two or more presses.

Powered conveyor track:

Powered track automates and simplifies press load handling for either end-loading or side-loading models. The track transports the load to the correct position in the press, eliminating manual positioning.

This arrangement also facilitates handling heavy loads and maintains stack alignment.

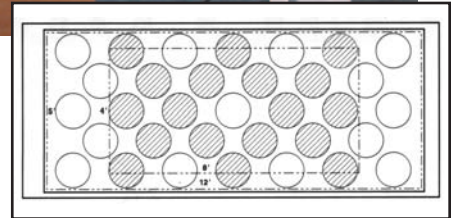
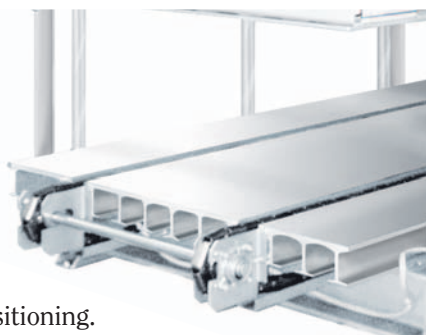

Zone Control:

Individual pressure control to combinations of pods

allows precise bonding of either full or smaller-than-platen size loads. This feature can be tailored to the customer's specific requirements and/or numerous load variations.

Computer Controls:

This system allows for pre-programming part sizes, pressures, and time sequences – very desirable when producing a variety of different material sizes and configurations requiring multiple adjustments – to increase output while reducing operational costs. The computer automatically loads the stack to the proper location in the press and applies the correct amount of pressure. Guesswork and time-consuming manual calculations are eliminated.

In addition, multiple platens and zone control are easily monitored by the computer. Programs can be modified as presses are added to the laminating system, allowing one computer to control multiple presses. The computer controls can be further expanded to control an entire Cold Press Laminating System.

Other optional features include:

- Larger-than-life openings
- Cycle timers
- Material handling equipment
- Pressure Reminder Light
- Auto Zone
- Semi-auto Load Adjustment Feature

Customizing Air Pod Press Arrangements Specifically For You

When a standard press model just won't do, let our experienced engineering and manufacturing groups custom design and build the right arrangement to meet whatever special needs your job requires.

Giant-Size Press for insulated wall panels.

This 8' x 28' (2438 mm x 8534 mm) press was designed to laminate SIP building panels. In addition to panel fabrication, it can be used as a clamping jig for bonding 4' wide stacks of material side-by-side in various lengths, up to the full capacity. One master control panel operates the press for maximum versatility. Presses up to 10' x 42' (2540 mm x 12 800 mm) have been constructed. Let Black Bros. engineers work with you to develop just the right configuration to meet your specific job requirements.

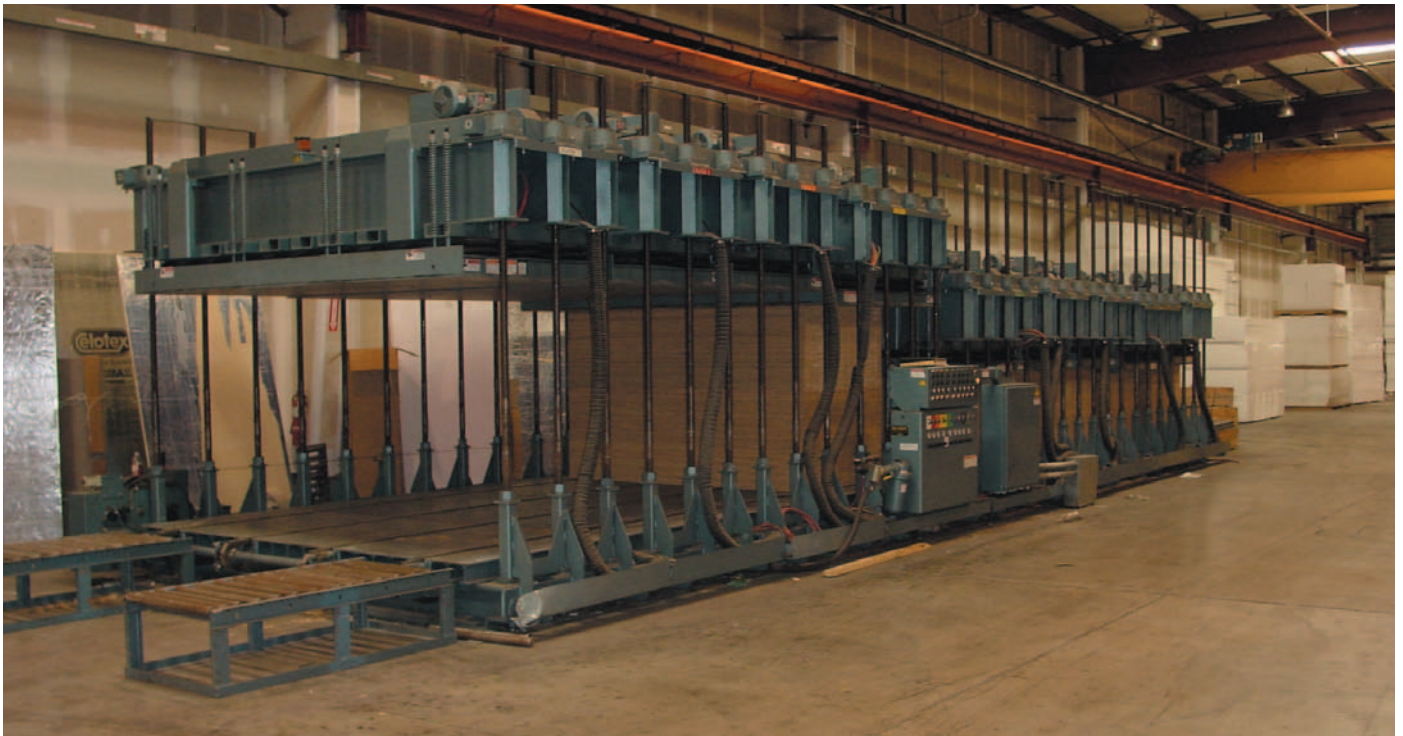

Other Custom-Engineered Press Designs:

- Heated Platen Presses
- Door Presses
- Combination of two or more standard presses for laminating larger stock
- Specialty standard unit arrangements

Black Bros. Power Pod Presses For Lighter Schedules

The Black Bros. Power Pod Press offers customers a low-priced, moderate pressure press arrangement. The 28" (711 mm) high opening is designed to laminate one stack of boards at a time (up to 34 - 3/4" thick panels). Up to 40 PSI of regulated laminating pressure can be developed, adequate for laminating HPL to particleboard or MDF. A fixed opening design keeps cost to a minimum. The press is offered in two popular sizes, 4' x 8' (1219 mm x 2438 mm) and 5' x 12' (1524 mm x 3658 mm) designed to meet the needs of the smaller shop, or a larger shop with small-to-moderate laminating requirements.

6



1. Simple control panel



2. "Power Pods" provide uniform pressure over the entire platen area

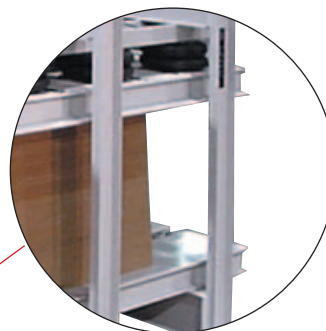
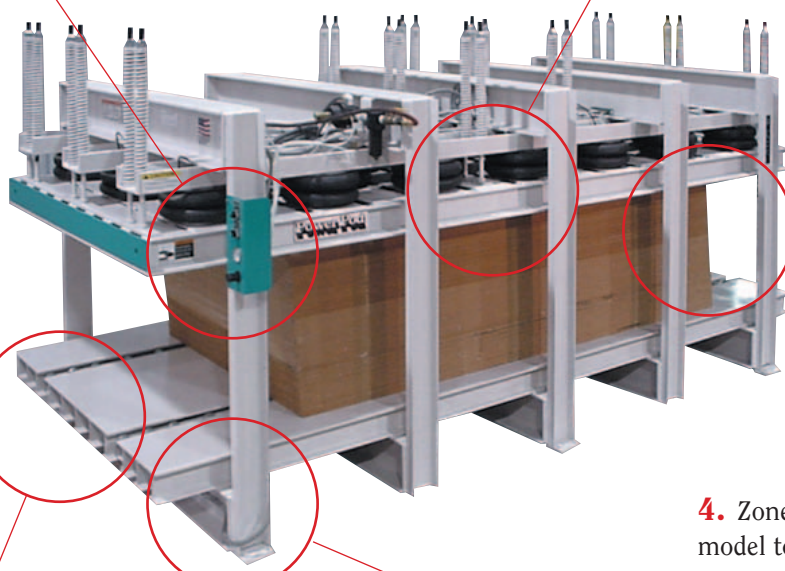

3. Pre-set 28" (711 mm) opening to accommodate a full bunk of board for each pressing cycle

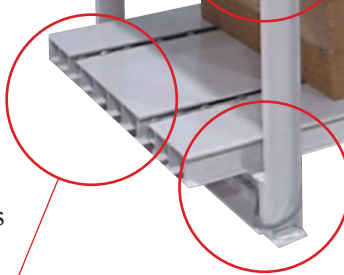

5. Retractable rollers in lower platen to assist in material handling

4. Zone control available on larger model to allow pressing shorter, narrower material

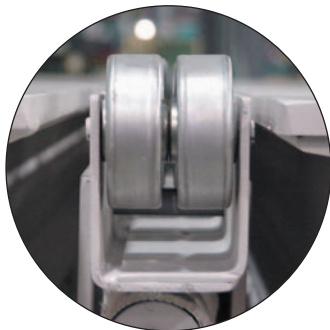
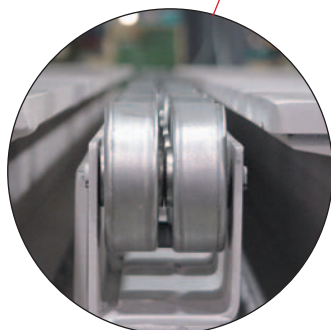

6. Rigid welded frame design

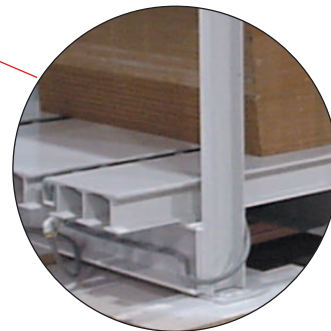

Joos Hot Press Elkom Ökotherm Plus Heating System

Black Bros. offers the Joos Hot Press for veneer panel lamination. These quality machines feature accurate and responsive Elkom Ökotherm platens. Most often used in the lamination of small batch, high end architectural panels and composite material. The press is equipped with hard, high-quality anodized hot water heating platens.

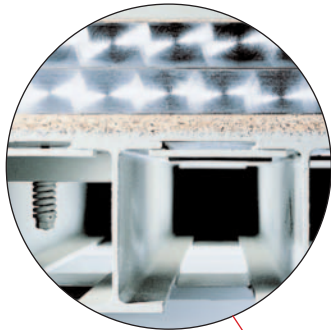

1. Table
Extremely rigid and offers long term surface protection



2. ABS
Prevents the costly consequences of damage to the press table when imbalanced loads are applied.

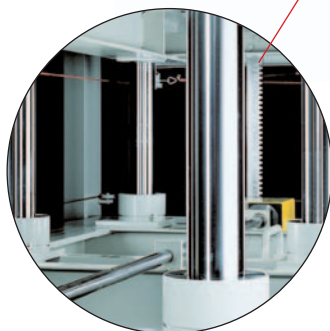
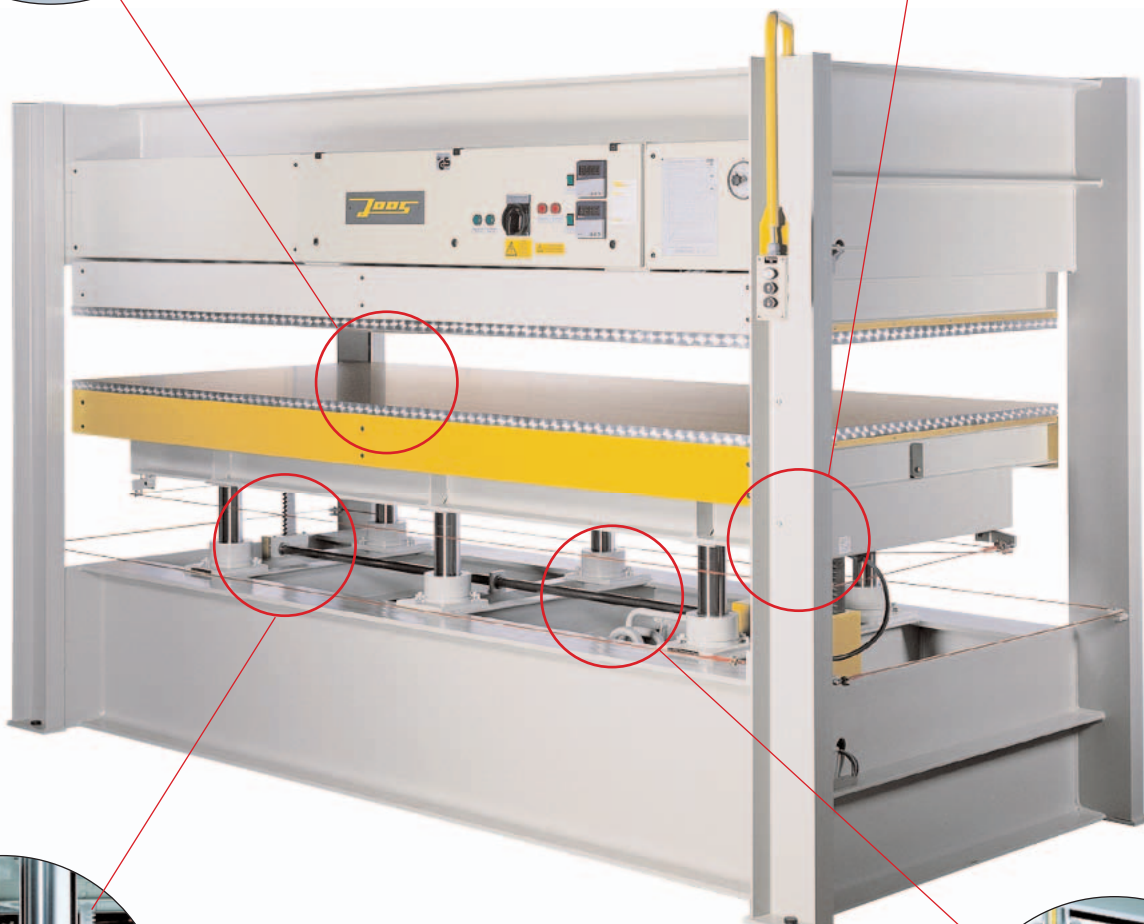

3. Cylinder
Dynamic Piston Bearing System allows for thermal expansion of press table in all directions.

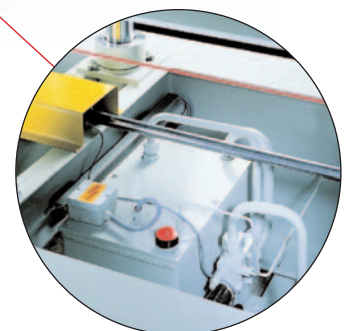

4. Hydraulic
Efficiently produces uniform pressure.